

# OWNER'S MANUAL

BIONEST™ WASTEWATER TREATMENT SYSTEM

MODELS:

BN-400

BN-500

BN-600

BN-750

## TABLE OF CONTENTS

1.0	SAFETY INFORMATION .....	4
2.0	HOW DOES THE BIONEST™ SYSTEM WORK? .....	5
2.1	BIONEST™ Wastewater Treatment System Diagram .....	5
2.2	BIONEST™ System Model Designation .....	6
2.3	Identification Plate .....	6
3.0	IMPORTANT INSTRUCTIONS .....	6
4.0	SYSTEM INSPECTION GUIDELINES.....	7
4.1	Maintenance Agreement.....	8
4.2	Septic Tank.....	8
4.3	Effluent Filter.....	8
4.4	Air Pump.....	8
4.5	Audible and Visual Alarm System.....	9
4.6	Recirculation Pump.....	10
4.7	Sludge Removal Device .....	11
5.0	SERVICING THE BIONEST™ SYSTEM .....	11
6.0	INTERMITTENT USE AND EXTENDED NON-USE PERIODS.....	11
7.0	PUMPING STATION AND OTHER EQUIPMENT .....	11
	LIMITED WARRANTY .....	12
	OWNERSHIP TRANSFER FORM.....	15

This manual includes all the necessary information for the operation and maintenance of the BIONEST™ system. An authorized BIONEST™ installer must perform the installation of the system. To get a list of authorized installers or to reach our service team, please contact us:

Bionest Distribution Inc  
2147 Petawawa Blvd

Pembroke, Ontario K8A 7G8

☎ 613.735.5203 / 1.866.477.5203

📠 613.732.1881

[inquiry-on@bionest.ca](mailto:inquiry-on@bionest.ca) ♦ [www.bionest.ca](http://www.bionest.ca)

Dear Customer:

Thank you for purchasing our Class III Wastewater Treatment System and for the confidence shown in our team of professionals.

You will find, in this document, important guidelines to follow for the use and maintenance of the BIONEST™ system. Please take time to read it carefully in order to ensure the safe and proper operation of your system.

If you have any questions after reading this document or if you need any further information, please do not hesitate to call our customer service representative at: **1.866.477.5203** or visit our website at: [www.bionest.ca](http://www.bionest.ca)

### Warning: What to do in case of a system failure?

Your BIONEST™ system comes equipped with an audible and visual alarm system that is installed in your residence. This alarm will indicate any problem with the air pump and/or the recirculation pump. If the alarm emits an audible and stringent sound, please contact your BIONEST™ installer immediately or Bionest at **1.866.477.5203**

You must also contact your septic system installer or Bionest if you notice any of the following:

- ⇒ If toilets or other water fixtures back-up or overflow back into the house
- ⇒ Abnormal odors inside or around the house, or coming from drinking water sources
- ⇒ Effluent or sewage appearing at the surface of the yard where the septic tank, the BIONEST™ system, or the polishing field is installed
- ⇒ The grass on top or around the septic tank, the BIONEST™ system, or the polishing field is abnormally thick and of a dark green color
- ⇒ Your residence or yard is flooded.

#### DANGER!



Pipes and electric cables are buried close to your septic installation. Please contact your installer or Bionest before digging or undertaking any excavation work in the area surrounding your septic installation. Otherwise, you are at risk of serious electrical shock.

## 1.0 SAFETY INFORMATION

Please read and follow the precautions listed below, as well as those found throughout the Owner's Manual. If you have any questions regarding the safety or operation of your BIONEST™ wastewater treatment system, please contact us at: **1.866.477.5203**

→ **DANGER:** Always disconnect the power supply cord before servicing any unit. Failure to do so may result in electrical shock causing serious bodily injury or death. All work must conform to local electrical, plumbing and building codes.

→ **DANGER:** If contact with wastewater occurs, please remove any contaminated clothing and thoroughly wash all body areas and clothing exposed to wastewater with soap and water. To minimize any risk of illness, consult a physician.



Please ensure that both tanks have been filled with clear water before starting the system.

In the case of a new construction, wait until the residence is occupied.



The use of your system when the air pump is not functioning can result in serious consequences (e.g. clogging of the polishing field and/or cancellation of your warranty).

For intermittent use and extended non-use periods please refer to section 6.0 of this manual. Always advise Bionest before shutting down your system.



Please ensure easy access, at all times, to the covers of both the septic tank and the bioreactor, for inspection and/or emergency purposes.



Please ensure that the audible and visual alarm system is connected to a dedicated electrical circuit breaker; do not connect it to the electrical circuit dedicated to the air pump(s) and/or the recirculation pump.

## 2.0 HOW DOES THE BIONEST™ SYSTEM WORK?

The BIONEST™ system is a submerged fixed film bioreactor using a non-biodegradable media. The wastewater treatment is accomplished through two identical tanks installed side by side.

The primary treatment uses a conventional two compartment septic tank equipped with an effluent filter.

The advanced secondary treatment is performed in the BIONEST™ bioreactor, a tank identical in size and form to the septic tank. The BIONEST™ media is installed inside the two compartments of the tank which are both equipped with sludge removal devices.

Continuous aeration of the first compartment of the bioreactor is provided with a linear air pump and with bubble air diffusers. A recirculation pump is installed in the last compartment of the tank and returns part of the effluent of the bioreactor to the first compartment of the septic tank.

## 2.1 BIONEST™ Wastewater Treatment System Diagram

FIGURE 1: ILLUSTRATION OF THE BIONEST™ WASTEWATER TREATMENT SYSTEM

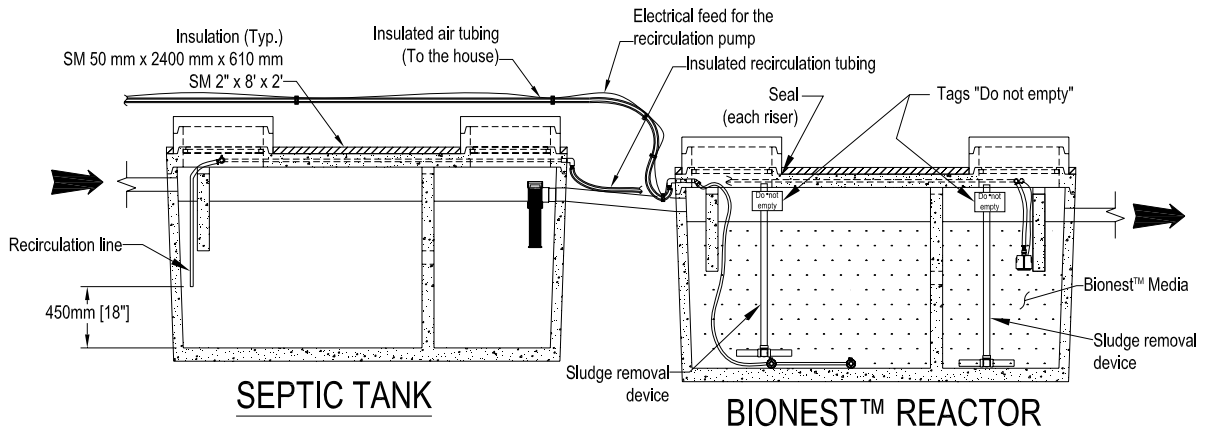
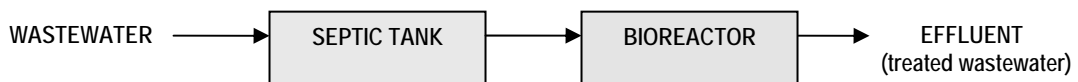

FIGURE 2: WASTEWATER FLOW PATH



## 2.2 BIONEST™ System Model Designation

BIONEST™ systems are designed and dimensioned according to the amount of wastewater to be treated, as illustrated in the following table.

TABLE 1: MODEL DESIGNATION

Model Number	Daily flow (Litres per day)	Tank Size - Minimal effective capacity (Cubic meters)
BN-400	1 600 L	3,8 m <sup>3</sup>
BN-500	2 000 L	4,7 m <sup>3</sup>
BN-600	2 500 L	5,1 m <sup>3</sup>
BN-750	3 000 L	5,7 m <sup>3</sup>

**Note:** To identify which model you have purchased, please refer to the system identification plate located near the control panel.

## 2.3 Identification Plate

The identification plate is located on the panel of the alarm system (BIOLARM™) found within the residence or serviced building. Information that identifies the unit is found on this plate. If you contact Bionest or its representative, the service technician may request information found on this plate.

## 3.0 IMPORTANT INSTRUCTIONS

To ensure the best performance of your BIONEST™ wastewater treatment system:

**DOT NOT use or discard any of the following products into the sinks, toilets, or other water facilities within your residence:**



- ⇒ Caustic products used to unclog pipes such as: Liquid Plumr®, Drano®, etc.
- ⇒ Petroleum based products, paints, solvents etc.
- ⇒ Pesticides
- ⇒ Backwash effluents of a water softening system
- ⇒ Large quantities of bleaching products
- ⇒ Oil and grease (engine, cooking, etc.)
- ⇒ Wax and resins
- ⇒ Septic tank treatment products
- ⇒ All non-biodegradable objects (cigarette butts, sanitary napkins/products, etc.)

➔ **WARNING:** The discharge of any of the aforementioned products into the system may destroy the bacterial culture responsible for treating the wastewater and henceforth cause the system to be **non-operational**.

**PLEASE:**

- ⇒ Respect manufacturers' recommended usage for domestic cleaning products and avoid all antibacterial products.
- ⇒ Do not use automatic toilet cleaners.
- ⇒ Do not use a waste disposal unit in the sink (e.g. In-Sink-Erator).

➔ **WARNING:** For inspection purposes, the BIONEST™ wastewater treatment system must be accessible at all times. **It is the owner's responsibility** to ensure easy access to all the covers<sup>1</sup> of the BIONEST™ system.

**DO NOT:**

- ⇒ Connect drain pipes or gutters to the septic installation.
- ⇒ Modify the configuration of the septic and/or BIONEST™ treatment system installation. If you perform landscaping work, remember to inform your contractors as to the location of your septic and BIONEST™ treatment system installations.
- ⇒ Drive or park vehicles closer than 3m (10 feet) from the location of the BIONEST™ system installation.
- ⇒ Place objects that weigh more than 200 kg (500 pounds) near the system. All heavy materials such as earth, rock piles or shoveled snow should not be placed closer than 3m (10 feet) from the BIONEST™ system installation.
- ⇒ Plant trees closer than 3m (10 feet) from the installation.

➔ **WARNING:** The owner should not open any of the BIONEST™ system covers and handle any of its components without specific authorization.

#### 4.0 SYSTEM INSPECTION GUIDELINES

This section deals with procedures to be followed for proper system inspection and maintenance. Important instructions are also found under section 3.0 of this manual, to ensure adequate system performance.

---

<sup>1</sup> Please note that **additional charges will apply** if the covers are not accessible during the inspection of your BIONEST™ system. The four covers must be accessible, at all times, including a 10 cm (3 inch) clearance around the covers.

#### 4.1 Maintenance Agreement

The Bionest Maintenance Agreement consists of an annual inspection of the BIONEST™ system and its components. However, the Maintenance Agreement does not exempt the owner to respect current legal requirements which apply, particularly those concerning sludge removal and effluent standards. The owner is also responsible for the use and maintenance of the system in compliance with the information herein.

Every year, an inspection of the following elements must be carried out by Bionest or its representative:

- ⇒ Effluent filter
- ⇒ Air pump(s)
- ⇒ Recirculation pump
- ⇒ Alarm system

If requested, Bionest will provide the owner with a copy of the inspection report.

#### 4.2 Septic Tank

The septic tank must be pumped out periodically by complying with the province's existing norms and regulations. While Bionest recommends that the septic tank be pumped out when the sludge level is at or above 30 cm (12 inches), any local norm and/or regulation with stricter requirements will supersede this recommendation.

Please note that the emptying of your septic tank must be carried out by a specialized firm. Do not hesitate to contact Bionest for a list of the specialized firms in your area.

#### 4.3 Effluent Filter

Following the recommendations of the effluent filter manufacturer, the filter should be cleaned every time the septic tank is inspected or pumped out. Please inform the person in charge of emptying your septic tank that your system is equipped with an effluent filter.

During the annual inspection of the BIONEST™ system, Bionest or its representative will inspect and clean (if necessary) the effluent filter.

For more information, contact your local system installer or Bionest.

#### 4.4 Air Pump

The air pump supplies oxygen to the wastewater treatment system. When operating, the air pump usually emits a humming sound. If the air pump is not operating normally, the alarm system will be activated and notify the owner by a strident sound (see following section for more details).

The air pump foam filter must be cleaned at least once a year. This is a regular procedure, effectuated by Bionest during the annual maintenance and inspection of the system. However, depending on



general conditions around the air pump (e.g. dusty surroundings), it may be necessary for the owner to carry out a second cleaning during the year. To do so:

- ⇒ Disconnect the air pump's electrical power supply cord;
- ⇒ Remove the screw from the top cover and remove the foam filter;
- ⇒ Remove all the dust by vacuuming the filter;
- ⇒ If the filter is heavily soiled: hand wash in soapy water, rinse with clear water and **let dry before reinstalling**;
- ⇒ Reinstall the filter and remember to screw the cover back in place by making sure that the small notch aligns with the tab when fastening the cover to the casing;
- ⇒ Reconnect the air pump. Also reconnect the alarm system if it was disconnected.

Please make sure that the air pump is installed in a place where the ambient air temperature is adequate (at least 15°C).

#### 4.5 BIOLARM™ System

BIONEST™ systems come equipped with an audible and visual alarm system capable of detecting malfunctions of the electrical components. This alarm system connects directly to a regular 120 V outlet and sends out an audible signal in case of a malfunction. An indicator light will go on when one of the following problems occurs:

-  ⇒ Pressure problem in the air supply line
-  ⇒ Malfunction of the recirculation pump

To ensure the alarm system is functioning properly, a test will be performed during the annual inspection. If you desire to perform this test yourself, follow these procedures:

- ⇒ Disconnect the air pump's electrical power supply cord;
- ⇒ Wait a few minutes (up to 15 minutes) for the air pressure to decrease in the supply line; take advantage of these few minutes to clean the air filter such as described in 4.4;
- ⇒ You should then hear a strident noise confirming the proper operation of your alarm system;
- ⇒ Reconnect the air pump to the power supply outlet.

→ If the warning device does not emit an audible sound after the waiting period is over, please contact Bionest at: 1.866.477.5203

FIGURE 3: ILLUSTRATION OF THE BIOLARM™ SYSTEM

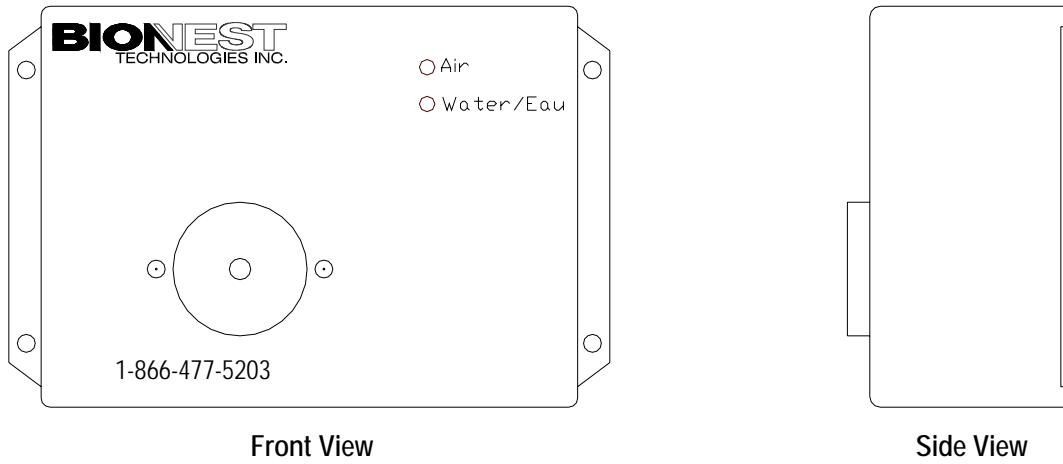
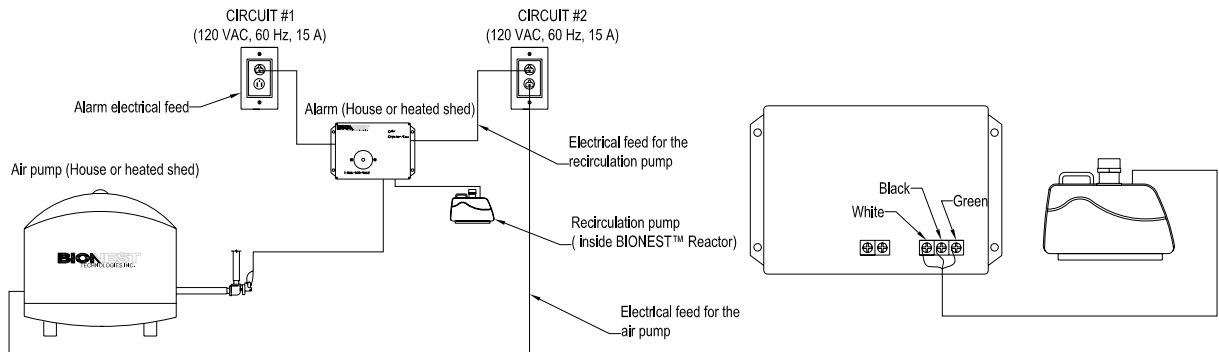

FIGURE 4: ELECTRICAL CONNECTION



→ Please ensure that the alarm system is connected to a dedicated electrical circuit breaker; **do not** connect it to the electrical circuit dedicated to the air pump and/or the recirculation pump.

#### 4.6 Recirculation Pump

The recirculation pump is installed in the second compartment of the bioreactor and allows a permanent recirculation of the effluent back into the septic tank. In the event that the recirculation pump stops working, the alarm system will emit a warning signal.

#### 4.7 Sludge Removal Device

The BIONEST™ wastewater treatment system has been designed so that only the septic tank requires periodic sludge removal (see section 4.2). When used accordingly, there should be little or no sludge accumulation in the bioreactor. However, sludge removal devices have been integrated into the bioreactor to ensure easy sludge removal in case toxic and/or prohibited products are disposed of into the residence's water facilities. If the system is improperly used as stated above, this will destroy the microorganisms responsible for effective wastewater treatment and cause the BIONEST™ system to malfunction.

In the event the septic tank has not been serviced for sludge removal within the timelines required by local regulations, or if there is abnormal sludge accumulation noticed in the effluent filter when sludge is being removed, please contact your local installer or Bionest.

#### 5.0 **SERVICING THE BIONEST™ SYSTEM**

BIONEST™ systems operate automatically and require no individual-specific intervention. When the system is functioning properly, no odours should be perceived. If odours do occur, make sure the air pump is functioning normally. If not, please call your local installer or Bionest.

→ **DO NOT** attempt to service any of the BIONEST™ system components yourself.

#### 6.0 **INTERMITTENT USE AND EXTENDED NON-USE PERIODS**

Even if wastewater does not enter the BIONEST™ system for an extended period of time, the system will function properly. The power should be left on during short periods of non-use when there is no water flow to the system (intermittent use).

If the property is going to be used seasonally (i.e. summer use only and closed for winter) and if the system is not in use for periods extending over 6 consecutive weeks, the air pump(s) may be shut down. The air pump(s) must be restarted immediately upon your return to the property.

#### 7.0 **PUMPING STATION AND OTHER EQUIPMENT**

For maintenance of the pumping station or other equipment being used with your BIONEST™ wastewater treatment system, please refer to the appropriate "User's Manual" supplied with the equipment.

## LIMITED WARRANTY

### 1. Preamble

The purchase of a BIONEST™ (BN model) wastewater treatment system from Bionest Technologies, hereinafter called *Bionest Technologies*, comes with an advantageous Warranty Certificate.

For the purposes of this Warranty Certificate, the term *Customer* means a person who has acquired a BIONEST™ (BN model) system, and the term *Successors* means any other person entitled to exercise the Customer's rights.

### 2. Nature of the Warranty

The purchase of a BIONEST™ Advanced Secondary Wastewater Treatment System, BN model, comes with a free inspection of all components during the first year following installation by an authorized representative of Bionest Technologies.

During the first year following the date of installation, Bionest Technologies offers a complete warranty on labor, free of charge. Bionest Technologies also warrants all of the BIONEST™ (BN model) system components for a period of TEN (10) years, and warrants the non-deterioration of its media for a period of TWENTY (20) years, from the date of purchase.

### 3. Notification Obligations

Your BIONEST™ (BN model) system comes equipped with an alarm system which is installed inside your residence. This alarm detects problems related to the air pump or the recirculation pump. If the alarm goes off, you must immediately notify Bionest Technologies.

Also, for this Warranty Certificate to be valid, the Customer must immediately notify Bionest Technologies of any apparent anomaly, irregularity, and/or malfunction of the BIONEST™ (BN model) system. If the customer fails to advise Bionest Technologies within a reasonable

timeframe, this Warranty Certificate may be considered null and void.

Upon receipt of the required aforementioned notification, Bionest Technologies will examine the situation and take appropriate corrective measures, within a reasonable timeframe, if the terms and conditions of this Warranty Certificate were applied accordingly.

The Customer must also provide access to the BIONEST™ (BN model) system, at all times, to Bionest Technologies or its representative.

### 4. Exclusions

The following damages or problems are excluded from the Warranty Certificate:

- a) Any damage or problem caused by a fortuitous event or an "Act-of-God", such as, and without limiting the generality of the foregoing: earthquakes, floods, hurricanes, landslides, explosions or dynamiting;
- b) Any damage or problem caused by the fault or act of a third party;
- c) Any damage or problem arising from any installation, modification, correction or addition carried out by a person not authorized by Bionest Technologies;
- d) Any damage or problem arising from any installation, modification, correction or addition carried out after installation of the BIONEST™ (BN model) system without Bionest Technologies' written approval;
- e) Any damage or problem caused by the use of a septic tank that does not comply with the *OBC* and/or *BMEC* requirements;
- f) Any damage or problem, if it is proven that the BIONEST™ (BN model) system was not used according to the terms and conditions stipulated in the Owner's Manual;

- g) Any damage or problem, if it is proven that the BIONEST™ (BN model) system was not used and maintained in compliance with the existing regulations, as well as the recommendations of Bionest Technologies;
- h) Any damage or problem, caused by the fault or action of the Customer or the Customer's Successors including, but without limiting the generality of the foregoing, refusal to allow access to the system for inspection purposes;
- i) Any action, damage or problem required in order to obtain access to one or any part of the BIONEST™ (BN model) system, which under normal conditions does not require any special action, including, but without limiting the generality of the foregoing, excavation, snow removal or demolition.

#### 5. Particular Exclusions

It is further expressly understood that the Customer may not carry out or cause to be carried out any repair, maintenance and/or verification of the purchased BIONEST™ (BN model) system, or attempt to carry out any work whatsoever or to apply any corrective measures whatsoever to the aforementioned systems (except for the air pump filter cleaning specified in section 4.4 of the Owner's Manual and for the emptying and sludge level measurements specified in section 4.2), before notifying Bionest Technologies in accordance with the provisions under section 3 of this Warranty Certificate and before Bionest Technologies has visited the installation, within a reasonable timeframe, following reception of the aforementioned notification, to assess the situation.

If the Customer carries out, attempts to carry out, or causes to be carried out any repair or any corrective measure whatsoever to the purchased BIONEST™ (BN model) system, without notifying Bionest Technologies as stated above, this Warranty Certificate shall be considered completely discharged from all obligations under this warranty.

#### 6. Indemnities and Damages

The liability and obligations of Bionest Technologies under this Warranty Certificate for corrective measures and/or means of correcting a problem, of which it is duly advised, shall be limited to the replacement of one or any component of the BIONEST™ (BN model) system, in compliance to sections 3 and 4 herein.

#### 7. Damage Limitations

Bionest Technologies may in no way be held liable for any other damage sustained by the Customer. Bionest Technologies' compensation or indemnification obligation shall be limited to the provisions under section 6 of this Warranty Certificate.

Bionest Technologies does not assume any liability for personal injury or property injury caused by the use or misuse of the BIONEST™ (BN model) system. Bionest Technologies shall not, in any event, be liable for special, incidental, indirect, or consequential damages. Bionest Technologies' liability shall, in all instances, be limited to the provisions under section 6 of this Warranty Certificate and will terminate upon expiration of the applicable Warranty Certificate period.

#### 8. Ownership Transfer

In the event of the Customer's transfer of ownership, sale, reassignment or disposition in any other way of the Customer's property to a third party, this Warranty Certificate shall continue to apply on the express condition that the new owner confirms in writing to Bionest Technologies that he is the new owner of the property, is cognizant of the Warranty Certificate and accepts its terms and conditions.

The Customer agrees to forward, to the buyer or the buyer's successors, the present Warranty Certificate, as well as the Owner's Manual, that were remitted to the Customer upon completion of the installation.

For the provisions of the first paragraph of this section to apply, the Customer or any of the

Customer's Successors must, within a reasonable timeframe, complete the *Ownership Transfer Form* on the last page of this Warranty Certificate and return it immediately to Bionest Technologies. The Customer may also opt to write to Bionest Technologies, notifying the latter of the transfer of ownership, and provide the new owner's complete name, mailing address, and valid phone number, as well as an acknowledgment of the remittance of the Owner's Manual and Warranty Certificate.

If the Customer, Successors or new owner does not send the *Ownership Transfer Form* duly completed, or a written notification as stated above, this Warranty Certificate shall no longer prevail and shall be considered null and void.

#### 9. Inspection

The Customer or the Customer's Successors shall allow Bionest Technologies or its duly authorized representative to perform all necessary monitoring and/or inspection measures, when deemed necessary, for the assessment and validity of this Warranty Certificate.

If the Customer or the Customer's Successors requests an inspection by Bionest Technologies in regards to a warranty claim, and it is found upon duly authorized inspection, for the validity of the aforementioned warranty claim, that the BIONEST™ (BN model) system is performing in accordance to the standards, regulations and specifications herein, a minimum charge of \$100, plus direct expenses, will be invoiced to the Customer and/or the Customer's Successors for the cost of such an inspection.

If the BIONEST™ (BN model) system is not performing as specified above, no charges shall be applied.

#### 10. Interpretation

The terms of this Warranty Certificate shall be interpreted according to the laws of the Province of Ontario and the provisions herein.

#### 11. Priority of the Warranty Certificate

The Owner's Manual remitted to the Customer shall also be considered as supplementing this Warranty Certificate; in case of discrepancy between this Warranty Certificate and the Owner's Manual or other documents issued by Bionest Technologies Inc, the terms of this Warranty Certificate shall prevail.

#### 12. Purchaser and Successors

Subject to the provisions of this Warranty Certificate, and particularly under section 8, the terms and conditions of this Warranty shall continue to apply, to the purchaser and/or the Customer's Successors, in full effect until the end of the Warranty period stipulated under section 2 of this Certificate.

#### 13. Jurisdiction

The parties acknowledge that any litigation regarding the present Warranty Certificate must be introduced in the judicial district of Renfrew County.

**Ownership Transfer Form**

I, the undersigned, \_\_\_\_\_ hereby declare that I have acquired the property located at:

_____	_____	_____
<i>Street name and nº</i>	<i>City</i>	<i>Province or State</i>
_____	_____	( )
<i>Country</i>	<i>Postal code</i>	<i>Telephone of new owner</i>

and have read the Warranty Certificate provided by Bionest Technologies Inc regarding the BIONEST™ (BN model) Wastewater Treatment Systems. I therefore wish to benefit from this Warranty Certificate for the remaining warranty period, as stipulated in the certificate, as well as the maintenance agreement and I accept all terms and conditions therein.

I therefore request the acknowledgement of Bionest Technologies regarding this transfer of ownership.

_____	_____	_____
<i>Complete name of new owner</i>	<i>Signature of new owner</i>	<i>Date</i>
Name of previous owner: _____	_____	( )
		<i>Telephone of previous owner</i>



**Ownership Transfer Form**

I, the undersigned, \_\_\_\_\_ hereby declare that I have acquired the property located at:

_____	_____	_____
<i>Street name and nº</i>	<i>City</i>	<i>Province or State</i>
_____	_____	( )
<i>Country</i>	<i>Postal code</i>	<i>Telephone of new owner</i>

and have read the Warranty Certificate provided by Bionest Technologies Inc regarding the BIONEST™ (BN model) Wastewater Treatment Systems. I therefore wish to benefit from this Warranty Certificate for the remaining warranty period, as stipulated in the certificate, as well as the maintenance agreement and I accept all terms and conditions therein.

I therefore request the acknowledgement of Bionest Technologies regarding this transfer of ownership.

_____	_____	_____
<i>Complete name of new owner</i>	<i>Signature of new owner</i>	<i>Date</i>
Name of previous owner: _____	_____	( )
		<i>Telephone of previous owner</i>